



RELIABLE
STORAGE SYSTEMS

ELECTRIC RIDER PALLET TRUCKS



RMP / 2000 kg

*One Stop Storage Solution
In Material Handling Equipments*

► Overview

RMP20XUX

electric rider pallet truck
 MP20XUX delivers low cost of ownership, as well as boosting pallet transportation rates over both short and long distances. These sturdy trucks can optimise vehicle loading and unloading operations while providing the operator with optimum comfort.

► Productivity

- Advanced AC control system eliminates the motor brushes, which limits maintenance requirements
- Low skirtings on main chassis
- Side battery roll-out system is very convenient to replace batteries
- Built-in pressure relief valve protects the trucks from overloading
- Emergency power disconnect switch
- Long handle reduces steering effort
- Emergency reversing system in handle
- Low speed switch in the handle
- Variable speed control
- Cold store configuration (option)

► Optimum Structural Design

- Spring-loaded casters improve lateral stability on uneven floors and enhance truck performance and service life
- Formed heavy gauge steel provides maximum fork strength and longevity
- Pull rod design protects against bending
- Durable plastic covers

► Serviceability

- CANbus technology reduces wiring complexity
- Low battery protection setting extends the battery life
- All pivot points have grease fittings and serviceable bushing, reducing component wear



**Handle (Standard)
(Left & Right Handed)**



**Entry roller for
easy operation**

► Specifications and Dimensions

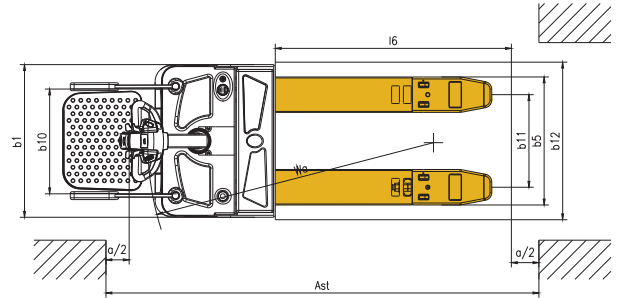
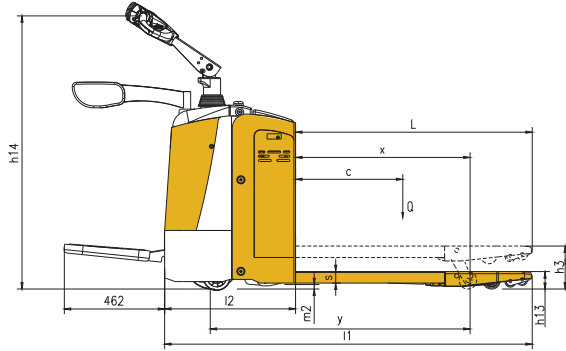

Model	Measurement	RMP20XUX
Load capacity	Q (kg)	2000
Load centre distance	c (mm)	600
Load distance, centre of drive axle to fork	x (mm)	815/865/935
Fork height, lowered	h13 (mm)	82
Tyre size, front	mm	250×70
Tyre size, rear	mm	82×126 (98)
Additional wheels (dimensions)	mm	127×57
Wheels, number front rear (x=driven wheels)		1X+2/2 (4)
Max.lift height	h3 (mm)	202
Height of tiller in drive position min./max	h14 (mm)	1150/1430
Overall length	l1 (mm)	1710/1760/1830
Length to face of forks	l1 (mm)	610
Overall width	b1 (mm)	775
Fork dimensions	s/e/l (mm)	53×180×1100 (1150/1220)
Width overall forks	b5 (mm)	520/550/650/685
Aisle width for pallets 1000×1200 crossways	Ast (mm)	1910/1960/2030
Aisle width for pallets 800×1200 crossways	Ast (mm)	2010/2010/2030
Turning radius	Wa (mm)	1550/1600/1670
Travel speed, laden/unladen	Km/h	7/7.1
Battery voltage, nominal capacity K5	V/Ah	24/210
Battery weight	kg	196
Battery dimensions l/w/h	mm	750×170×534
Service weight (with battery)	kg	720

Think outside the box



Drive-in Drive Thru Pallet Racking



Modular Mezzanine Floor



Narrow Aisle Pallet Racking

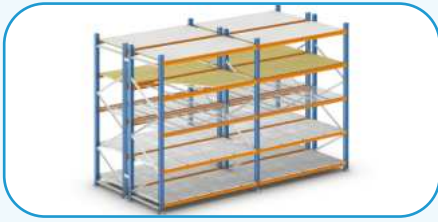

LONG SPAN SHELVING RACK



Boltless Long Span Shelving Rack



Multi Tier Long Span Shelving Rack



Cantilever Racking



M.S Powder Coated Cupboard



Rivet Shelving Rack



Mobile Shelving Rack, Compactor



M.S Powder Coated Lockers



Electric Forklift

www.reliablestorage.co.in



RELIABLE
STORAGE SYSTEMS

ADDRESS :- 103, Lake View Residency, Bhabola - Bangli Road,
Near Husaini Colony, Sandor , Vasai(W),
Dist. Palghar Pin.401 207 Maharashtra, India.

FACTORY :- Unit no. 15, 16, 17, 18 Mamta Compound,
Near Neel Kant Industrial Estate, Vilage
Devdal, Kaman, Vasai(E) - 401208 Maharashtra, India.

PHONE :- 98236 35153 | 98672 89052 | 9320011052

EMAIL :- sales@reliablestorage.co.in | inquiry@reliablestorage.co.in